



## MOUNTING NUTS

### Stud Nut

Part Number	Across Flats	Nut Thickness	Nut (Thread)
<b>N16-14</b>	1 1/2"	35/64"	1-14

### Rod Nut

Part Number	Across Flats	Nut Thickness	Nut (Thread)
<b>N08-20</b>	3/4"	5/16"	1/2-20

## CB-2495

Clevis Bracket  
Material: Steel, bright zinc plated

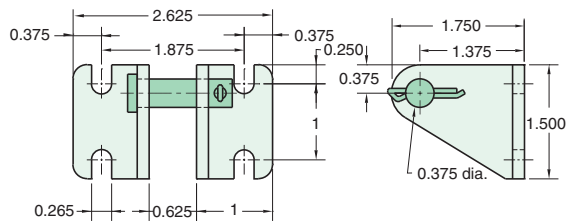

## RK-2899

Replaceable Rod Seal  
Material: Aluminum body

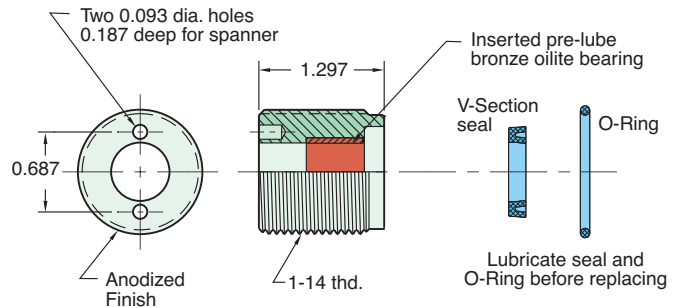

## RC-3281

Rod Clevis  
Material: Steel, electroless nickel plate

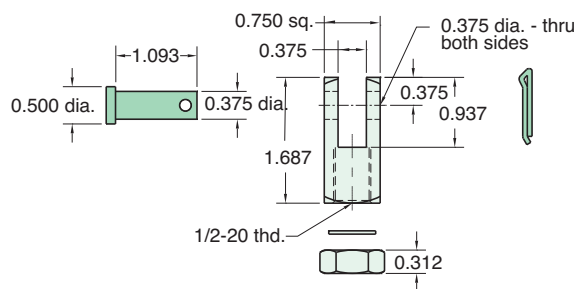

## RE-3285

Rod End  
Material: Steel, bright zinc plated body

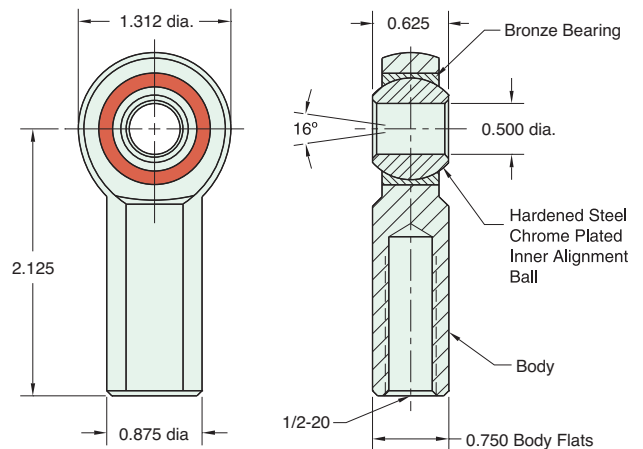

## FB-2891

Foot Bracket  
Material: Steel, bright zinc plated

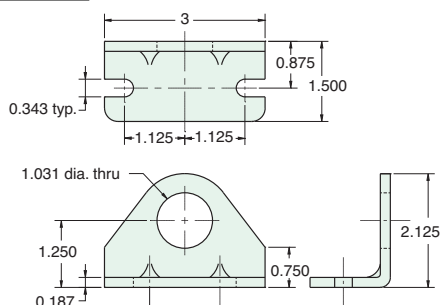

Lockwasher

Locknut

Max. Static Radial Load (rod end only): 6,700 lbs.  
Fits Rod Thread Size: 1/2-20